



Champ™ Stick 400

High Production - Heavy Duty - Industrial

Hot Melt Stick Gun

Part # G25E03-001



Operating Instructions

Hot Melt Glue Gun

Model: CHAMP™STICK 400

Glue Machinery Part # G25E03-001

Specification: AC 120 V 400W

Glue stick size: 1/2" (ø11.0~ ø11.5mm)

READ SAFETY RULES AND INSTRUCTIONS CAREFULLY!

WARNING:

- When using this hot melt glue gun, always follow basic safety precautions. This will reduce the possibility of accidental injury due to burns or electrical shock.
- Always wear safety glasses, protective gloves, and protective clothing with long sleeve shirts and pants.
- This product must have a ground connection.

Tips on Using:

The following guide provides helpful information for G25E03-001/CHAMP™ STICK 400 glue gun and hot melts adhesives.

1. The normal working time of the hot-melt is thirty (30) seconds. After the adhesive has been extruded onto the bonding surface, the part should be pressed together within fifteen to twenty (15-20) seconds. The bond will have about 90% of its bond strength in one minute.
2. The working time of the hot-melt can be extended to fifty to sixty (50-60) seconds by applying the adhesive in large drops (11mm diameter) or shortened to less than ten (10) seconds by extruding the adhesive in a thin line.
3. Large areas are difficult to bond because the adhesive often hardens before you have extruded the required amount. Use a higher volume hot melt system from Glue Machinery Corporation for these projects.
4. Preheating the bonding surface to slightly above room temperature will improve the bonding strength. This action is particularly important when gluing metal pieces.
5. The hot-melt adheres well to porous surfaces like paper, cloth, particleboard, and wood.
6. The hot-melt adhesives quick set time eliminates the need for clamps or other holding devices.
7. The hot-melt begins to soften when the temperature exceeds 140°F and should not be used for items that will be subjected to temperatures above that. Other hot melts are available with high softening points that must be processed with bulk Hot Melt Systems available from Glue Machinery Corporation.
8. Hot-melt adhesives can be used in place of nails, staples, tape, or liquid glue; however, they should not be used to replace structural fasteners where heavy loads are involved.
9. Glue can string from the nozzle. If your glue is stringing from the nozzle you may want to swirl the nozzle in a circular motion so the heat of the nozzle will cut the string. If the glue string lands on your component, allow the glue to cool, then use a hair dryer and blow off the glue string. Adjustments to the temperature and nozzle can also help reduce stringing.

Operation:

1. Plug the glue gun into any AC outlet with required specification; red light on means the power is on.
2. Allow the tool to heat for approximately 5 minutes. Insert a stick of adhesive (1/2"/11mm diameter) into the back of the tool.
3. When the gun is fully heated, squeeze the trigger slowly, until the melted material begins to flow from the nozzle. Release the trigger to stop the glue flow.
4. The output volume of the glue can be adjusted by adjusting the patented stroke adjuster screw.
5. Different nozzle tips are available for different gluing applications and output amount.
6. Use screwdriver to adjust the operating temperature for which that glue stick is designed. Gun temperature is adjustable from 284F to 428F (140C-220C)
7. Use the glue gun trigger to adjust the output and speed of the glue sticks.

Save these safety rules for future use:

1. It is normal for this tool to become quite warm during use. This is normal and does not indicate a problem.
2. The glue gun should be unplugged after use or if it will not be used within 1-hour period. The adhesive can be stored indefinitely in the unheated gun and re-melted by heating up the tool.
3. If you accidentally touch the molten hot glue, immediately immerse the affected area in cold water and call a doctor. The injured area should be attended by a medical professional.
4. Some materials are heat-sensitive and can be damaged by the hot nozzle or even the hot glue. Whenever possible, test a piece of scrap material or a hidden portion of the object being repaired.
5. If the supply cord is damaged, it must be replaced by the manufacturer or its service agent or a similar qualified person in order to avoid a hazard.

Read all Safety Instructions:

- **Work area.** This tool was designed to be used on a clean, dry work surface. Excessive dust and dirt may reduce the lifetime of this tool. Do not use in wet or damp locations. Your work areas should keep well lit.
- **This tool is recommended for indoor use only.** Do not use outdoors.
- **Keep children away.** Small children should be kept away from work area. Accidental contact with tool or extension cord should be avoided.
- **Glue gun storage.** After use, allow glue gun to cool completely prior to storage. When not in use, the glue gun should be stored in dry and secure location out of the reach of children.
- **Electrical cord precautions.** Do not carry the tool by the cord or yank to disconnect from the receptacle. Keep the cord away from the nozzle or other high heat sources. Periodically inspect the electrical cord for any sign of wear or damage.
- **Disconnect electrical power.** When not in use, before servicing, and when changing. Do not yank on cord to unplug from electrical receptacle.
- **Stay alert.** Pay attention to your work. Beware of any dripping hot glue from your project. Use common sense. Do not operate this gun when you are tired. Do not operate under the influence of alcohol or other drugs that may impair your physical abilities.
- **Do not touch the heated nozzle of the glue gun or the hot adhesive.** The operating temperature of this tool can be as high as 446°F (230°C).
- **Use recommended accessories.** Use only recommended adhesives in this glue gun. Putting other materials than recommended may result in accidental injury and permanent damage to the glue gun. For example: do not attempt to melt crayons or candles.
- **Never use the tool if it is damaged in any way.**
- **Hot melt adhesives are not a replacement for structural fastener.**
- **Hot melt glue should not be used for projects that will be exposed to extreme heat.** Some adhesive used with this glue gun can soften at about 140°F.
- ***Do not attempt to remove unused portion of a glue stick from the tool.***
- Do not expose the glue gun to extreme changes in temperature during or directly after use. Never immerse glue gun in water or other liquids to speed cooling process. Allow the gun to air cool only.
- Children should use this glue gun only under the direct supervision of a responsible adult.
- Do not leave the glue gun unattended while plugged in or in a hot condition.
- Make sure to have sufficient eye protective wear, like full mask, in order to avoid damaging materials entering and causing long lasting effect to eye area, during use.
- Use of Hot Melt Sticks with a diameter other than 11mm will damage the gun

Preventive Maintenance

1. To prevent the clogging of the glue gun, keep feeding mechanism and melt chamber free from dirt and other foreign debris. Store unused glue sticks in a clean environment.
2. Do not pull glue stick from the back of the glue gun. The feed mechanism may be damaged or impaired. If you desire to change types of glue, cut off the protruding end and feed the remainder through with the new type of glue.
3. Do not lay heated gun on its side. Keep the heated gun in an upright position, on the metal stand or workbench, with nozzle pointed down.
4. If melted glue has escaped from the melt chamber entrance and is interfering with the feed mechanism; allow gun to cool, and gently remove the obstructing glue.
5. Replace the nozzle if glue drips excessively. Do not attempt to change nozzle when glue is cold. To change, the gun must be heated until the glue is softened enough to remove nozzle (about 1 minute). Use gloves and with a wrench, remove the old nozzle. Flush glue through the gun, to clean out the melting chamber. Replace with a new nozzle. Tighten only until snug. Do not over tighten.
6. Keep outside of glue gun clean.
7. **Only use approved 11mm diameter stick glue with this gun**

➤ Champ™ Stick 400 Functions

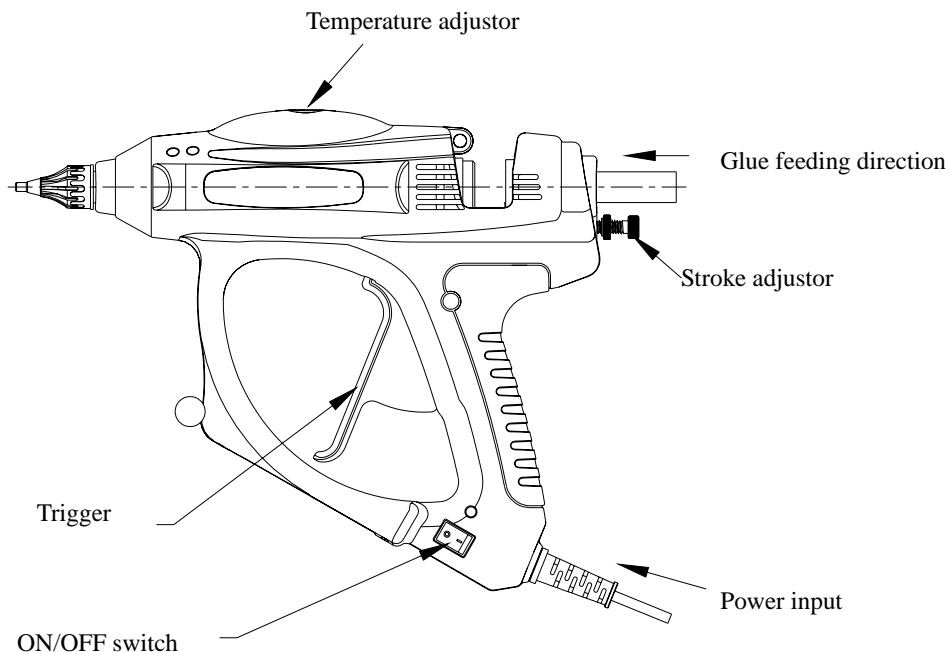

CHAMP™ STICK 400 Special features:

- 400 watts for greater glue output than other glue guns
- Non breakable handles and light weight
- Unique effort-saving trigger, with circular TPR handle for comfortable long hour operation
- Stroke adjustor: Each piece comes with a stroke adjustor, and allows user to pre-set the amount of glue output correctly.

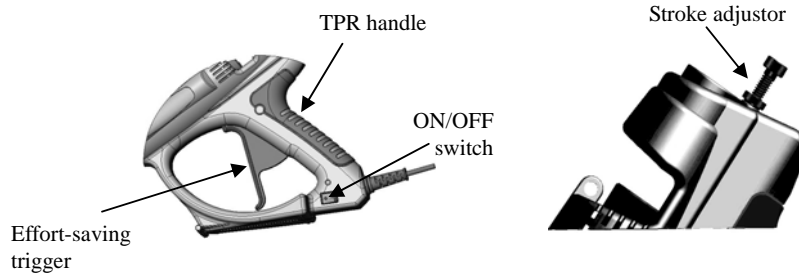

- Use of screwdriver for adjusting the temperature of glue gun between 140°C-230°C (284°F-446°F).
- Gun is preset to temperature 190°C (374°F).
- Screw driver can be stored easily at the base of glue gun.

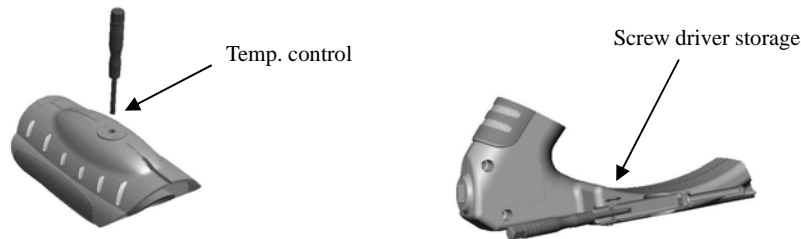

- Spare and replacement parts available from Glue Machinery Corporation

Recommended & Approved Adhesive Stick Reorder/Restock Part #'s:

| | |
|-------------------|--|
| G25A77-001 | 1/2" General Purpose White Stick Glue. Often used for plastic, ceramic, lightweight material, craft, cloth, wood, and paper. |
| G25A77-002 | Clear general purpose adhesive for plastic, wood, and paper. |
| G25A77-003 | Yellow colored 1/2" adhesive stick often used for Box Forming and Carton Sealing |

1/2" (11mm) Diameter Glue Sticks

CHAMP™ STICK 400 Schematic Diagram

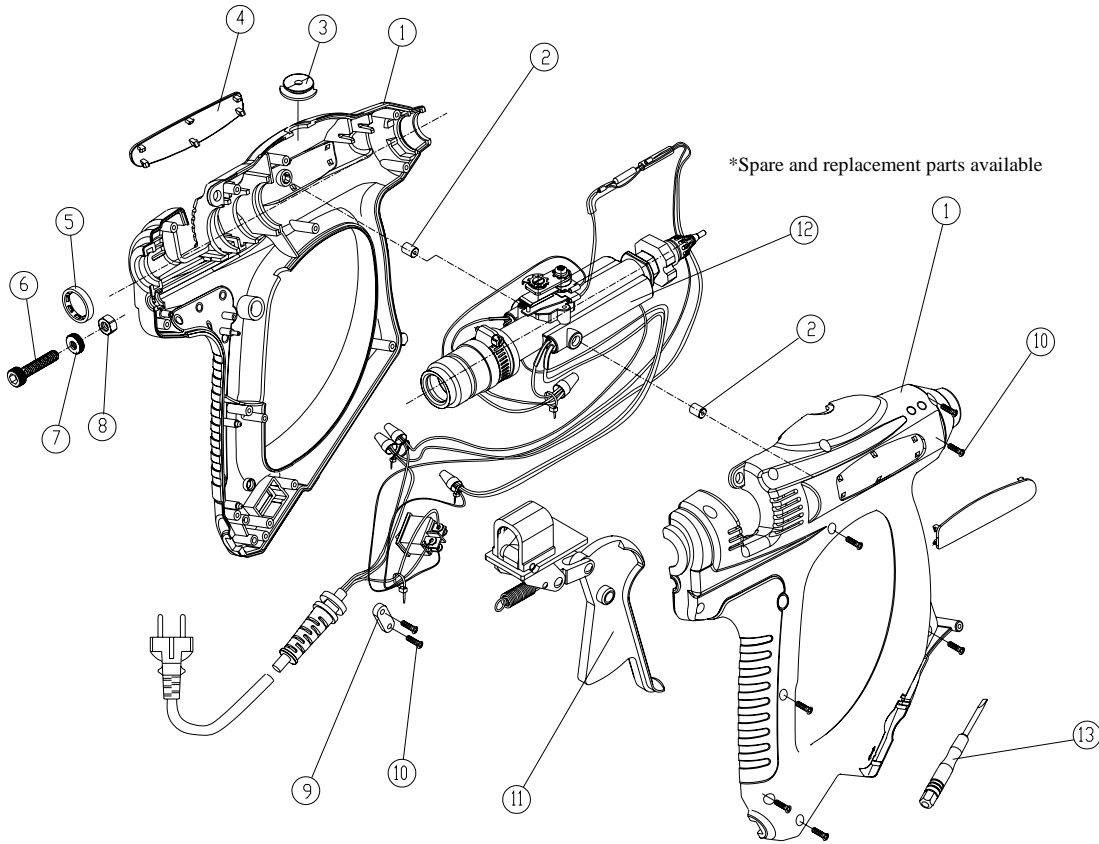

| No. | Name | Part No. |
|-----|--|--|
| 1 | Handle set | <i>Please call 1-888-202-2468 to order</i> |
| 2 | Locating post | <i>or email info@gluemachinery.com</i> |
| 3 | Temperature cap | <i>with diagram part (1-13) number</i> |
| 4 | Name plate | |
| 5 | O-ring | |
| 6 | Stroke adjustor screw | |
| 7 | Stroke adjustor nut | |
| 8 | Nut | |
| 9 | Cord fixer | |
| 10 | Screw | |
| 11 | Trigger set | |
| 12 | Heater Set | |
| 13 | Screwdriver/adjustment tool for temp control | |

Glue Machinery Corporation™

4234 Boston St, Baltimore, Maryland 21224

Toll Free 1-888-202-2468 | Phone: 410-761-2727 | Fax: 410-761-5127 | Email: info@gluemachinery.com

www.gluemachinery.com

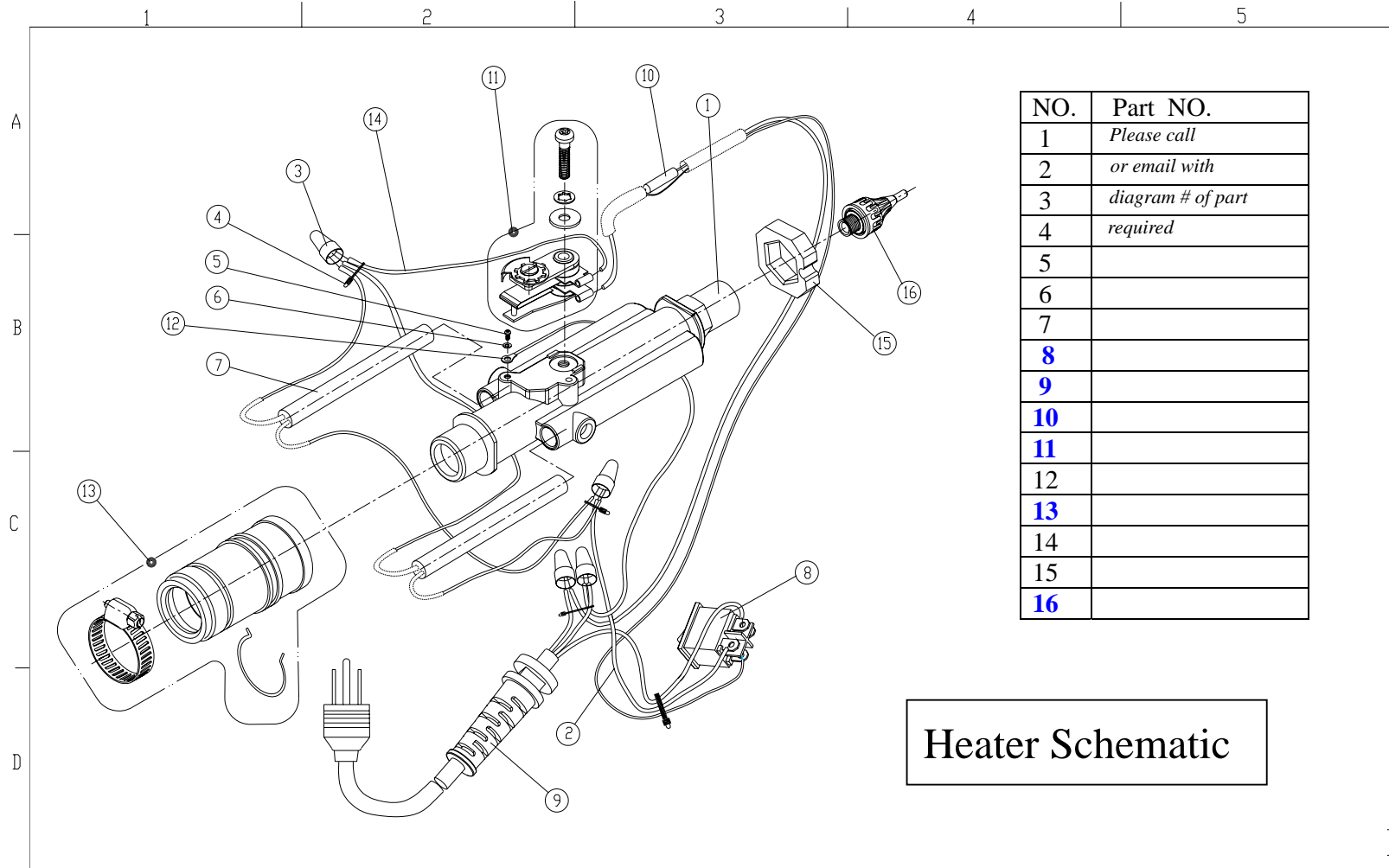

Heater Schematic

➤ **Electric wiring diagram:**

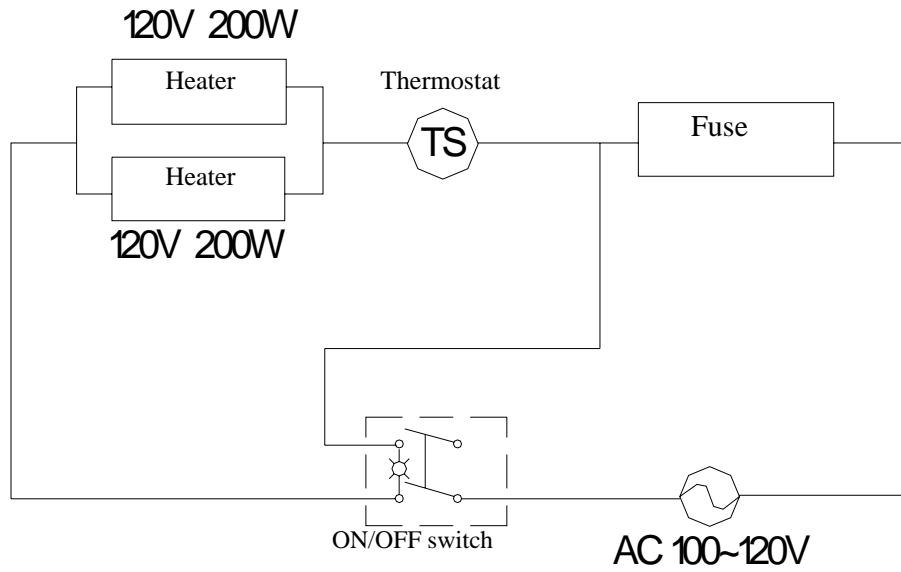

TERMS AND CONDITIONS OF SALE

1. **ENTIRE AGREEMENT:** These Terms and Conditions, together with terms on the face of Seller's invoice, shall constitute the entire and exclusive contract ("Agreement") between Seller and Buyer. This Agreement is intended to be a final expression of the parties' understanding and agreement with respect to its terms and shall supersede all prior negotiations, promises, agreements and representations not set forth herein. Seller's acceptance of Buyer's order is expressly conditioned on Buyer's assent to these Terms and Conditions of Sale. Any order, whether quoted, shipped or received by Seller, shall be construed as a written acceptance by Buyer of Seller's offer to sell in accordance with this Agreement, and any such order shall be filled in accordance with the terms as provided in this Agreement. No other terms and conditions shall apply unless specifically accepted by Seller in writing. No modifications of this Agreement shall be of any force and effect unless such modifications are made in writing and signed by the party claimed to be bound thereby. Additionally, no modification shall be effected by an acknowledgment or acceptance by Seller of any oral or written purchase order from Buyer containing any different terms and conditions, and any such inconsistent terms and conditions shall be deemed to be superseded by this Agreement and the other documents delivered by Seller to Buyer.

If for any reason Buyer fails to accept this Agreement in writing, any conduct that demonstrates the existence of a contract, including, without limitations, the delivery of items in accordance with this Agreement prior to written acceptance hereof and acceptance of such items by Buyer, shall constitute an agreement to all of the terms and conditions stated herein.

2. **PRICE:** The prices set forth on the face of Seller's quotation or invoice is only for the quantities of items listed and the specifications indicated. Except as otherwise indicated on the face of Seller's invoice, Buyer is responsible for all freight and transportation charges, and all items will be billed at the prices (including applicable freight and transportation charges) in effect as of the date of shipment. All prices and extras, including all freight and transportation charges, are subject to change by Seller at any time without prior notice. In addition, all prices are subject to the addition of an applicable use, sales, excise or other taxes levied by any federal, state or local authority, and Buyer shall be responsible for any such taxes. Any excises, levies or taxes which Seller is required to pay or collect, under any existing or future law or regulation (domestic or foreign), upon or with respect to the sale, purchase, delivery, storage, processing, use, consumption or transportation of any of the items covered hereby, shall be for the account of Buyer and Buyer agrees to promptly pay the amount thereof to Seller upon request.
3. **DELIVERY AND RISK OF LOSS:** Unless otherwise stated in Seller's quotation or invoice, delivery shall occur, and risk of loss shall pass to Buyer upon delivery of the items to Buyer's designated delivery point. All items shall be delivered and shipped in accordance with the delivery schedule and instructions indicated on the face of Seller's invoice; provided, however, that delivery dates are approximate and are subject to reasonable variation.
4. **PAYMENT:** Unless otherwise specified, the terms of payment for each order under this Agreement shall be net cash in 30 days from the date of invoice. Any discount shall be on the purchase price only, exclusive of freight or transportation, taxes and other charges. The unpaid portion of any overdue amounts owed to Seller shall bear interest at the legal rate. Seller shall retain title to all items as security until payment for same has been received. If Buyer at any time fails to make payment as required under this Agreement, Seller may, in addition to any other remedies that it may have as provided by law or in equity, suspend its own performance hereunder and demand collateral sufficient to ensure the payment of all outstanding amounts that are then due and/or that may become due in the future under this or any other agreement between the parties.

Glue Machinery Corporation™

4234 Boston St, Baltimore, Maryland 21224

Toll Free 1-888-202-2468 | Phone: 410-761-2727 | Fax: 410-761-5127 | Email: info@gluemachinery.comwww.gluemachinery.com

5. **LIMITED WARRANTY AND DISCLAIMERS:** Subject to the limitations set forth in these terms and conditions, Seller warrants that the item(s) sold to Buyer will, under normal use and service, conform to any specifications that are listed in this Agreement. Seller reserves the right to change any of its specifications, if applicable, at any time. The limited warranty set forth in this paragraph expires at the earlier of (i) six months after date of shipment or (ii) the period or shelf life specified in the applicable Technical Data Sheet (the “Warranty Period”). This limited warranty is the sole and exclusive warranty provided under this Agreement and extends only to the original Buyer from Seller and does not extend to any subsequent purchases or any other uses of any item sold hereunder. No claim against Seller shall be allowed by any party other than the Buyer. **NO OTHER WARRANTY, WHETHER EXPRESS, IMPLIED OR STATUTORY, INCLUDING ANY WARRANTY OF MERCHANTABILITY, INFRINGEMENT, FITNESS FOR PARTICULAR PURPOSE OR OTHERWISE, SHALL EXIST IN CONNECTION WITH THE SALE OR USE OF ANY ITEM HEREUNDER. ADDITIONALLY, NO REPRESENTATION OR WARRANTY MADE BY ANY SALES REPRESENTATIVE OR SELLER WHICH IS NOT SPECIFICALLY SET FORTH HEREIN SHALL BE BINDING UPON SELLER.** All claims under this warranty must be made in writing and delivered to Seller at the address listed in Seller’s invoice prior to the expiration of the Warranty Period or such claims shall be barred.

The limited warranty provided for herein does not cover, and specifically excludes, material failure resulting from normal wear and tear, abuse, neglect, improper installation, faulty maintenance, accidental or intentional damage, damage from fire, floods, earthquakes or other acts of God, and/or defects resulting from seller’s compliance with Buyer’s specifications. Additionally, it is solely Buyer’s responsibility to test and determine the suitability of any item for any intended use, and although Seller may have recommended an item or developed an item at Buyer’s request, Buyer assumes all risk and liability whatsoever regarding the item’s suitability for Buyer’s or any other intended use.

6. **LIMITATIONS OF LIABILITY.** Upon receipt of a timely warranty claim from Buyer in accordance with these terms and conditions, Seller shall have the option either to inspect the item while in Buyer’s possession or to request Buyer to deliver the item to Seller at its factory or other designated site, at Buyer’s expense, for inspection by Seller. Seller shall, at its option, either (i) replace any item that has been properly selected, stored and used and is reasonably determined by Seller to be in breach of the warranty set forth in the foregoing paragraph of these terms and conditions, in which case seller shall then ship the replacement item to Buyer F.O.B. point of shipment; or (ii) if in Seller’s sole judgment circumstances are such as to preclude the remedying of a breach of any warranty by replacement, Seller shall refund to Buyer, by issuance of a credit or otherwise, the applicable part of the purchase price theretofore paid to Seller. **IN NO EVENT SHALL SELLER’S LIABILITY FOR ANY DEFECTIVE ITEMS UNDER THIS AGREEMENT EXCEED THE PURCHASE PRICE THEREOF. IT IS EXPRESSLY AGREED THAT REPLACEMENT OR REFUND OF THE PURCHASE PRICE SHALL BE THE SOLE AND EXCLUSIVE REMEDY FOR ANY BREACH OF WARRANTY OR ANY OTHER CLAIM IN RESPECT OF SUCH ITEMS, INCLUDING, WITHOUT LIMITATIONS, THOSE CLAIMS BASED ON CONTRACT, WARRANTY, TORT, OR STRICT LIABILITY. SELLER SHALL NOT UNDER ANY CIRCUMSTANCES BE LIABLE FOR REMOVAL OR INSTALLATION COSTS, DISPOSAL COSTS, LABOR COSTS, DOWNTIME, DAMAGE TO OTHER PROPERTY, LOSS OF BUSINESS OR PROFITS, OR ANY SIMILAR OR DISSIMILAR INCIDENTAL, SPECIAL OR CONSEQUENTIAL DAMAGES.** The sole purpose of the stipulated exclusive remedy set forth in this paragraph shall be to provide Buyer with free replacement or refund for defective items in the manner provided herein. This exclusive remedy shall not be deemed to have failed of its essential purpose so long as Seller is willing and able to replace defective items in the manner prescribed herein or to provide a refund if, in Seller’s judgment, replacement is not feasible or appropriate under the circumstances.

Glue Machinery Corporation™

4234 Boston St, Baltimore, Maryland 21224

Toll Free 1-888-202-2468 | Phone: 410-761-2727 | Fax: 410-761-5127 | Email: info@gluemachinery.com

www.gluemachinery.com

7. **ITEM RETURNS:** Seller, in its sole and exclusive discretion, shall have the right to accept returns of item(s) from Buyer during the applicable Warranty Period. No item shall be returned, however, unless (i) Seller has issued to Buyer a written return authorization number, (ii) Buyer has a valid receipt for the item, and (iii) the Warranty Period has not expired. Buyer shall be responsible for any costs and expenses associated with the return of any item, including, but not limited to, any applicable shipping costs and any costs associated with the proper disposal of the returned items.
8. **FORCE MAJEURE:** Seller shall be excused from, and shall have no liability for, any prohibitions, failures, interruptions or delays in the manufacture or delivery of any items which may be occasioned by matters beyond the control of Seller, including, but not limited to, any act of sabotage, fire, flood, storms, explosion, labor dispute, strike, work stoppage, riot, insurrection, war, act of, or priorities granted by request of or for the benefit, directly or indirectly, of any government body, authority or agency, shortage of raw materials or supplies, act of God, or any other causes beyond Seller's control. In the event of any such prohibition, failure, interruption or delay in manufacture or delivery, Seller may, at its option, extend the delivery time or cancel the order in whole or in part. **IN NO EVENT SHALL SELLER BE LIABLE UNDER ANY CIRCUMSTANCES FOR ANY INCIDENTAL OR CONSEQUENTIAL DAMAGES OR CLAIMS OR ANY NATURE RESULTING FROM FAILURE OR DELAY IN DELIVERY.**
9. **TERMINATION/CANCELLATION:** In addition to any other remedies that Seller may have as provided by law or in equity, if Buyer (i) fails to make any payment when due hereunder, or (ii) fails on request to give proper shipping instruction, or (iii) fails to accept delivery at times stated, or (iv) becomes insolvent or otherwise voluntarily or involuntarily becomes subject to any bankruptcy or receivership proceedings, or (v) otherwise fails to comply with any terms and conditions of any contract between Buyer and Seller, Seller shall have the right at its option to terminate this Agreement, recover damages and deduct any undelivered quantities of items from the total quantities of items to be furnished to Buyer, whether under this or any other contract between Buyer and Seller. Additionally, Seller may, at any time or times, suspend performance of any order or require payment in cash, security or other adequate assurance satisfactory to Seller when, in Seller's sole opinion, the financial condition of Buyer or other grounds for insecurity warrant such action.

Buyer shall not be permitted to modify or cancel its order without the prior written consent of Seller. In no event shall any order be modified or cancelled for any portion thereof already manufactured, blended or in the process of manufacture or blending at the time the request for modification or cancellation is received by Seller. Seller, in its sole and exclusive discretion, shall have the right to make exceptions to this cancellation/modification requirement upon such terms as are satisfactory to Seller and that will protect and indemnify Seller against all loss.

Seller intends to comply with all federal, state and local laws and regulations applicable to the performance by Seller of each order, but any failure of Seller to so comply shall not be a defense to, or excuse Buyer from, performance by Buyer of any order.

10. **INDEMINIFICATION:** Seller shall not be liable for any inaccurate, incomplete, or faulty specifications supplied by Buyer, nor will seller be liable for any infringement or alleged infringement of any patent, trademark, design, or other intellectual property rights arising out of Seller's compliance with Buyer's specifications. To the fullest extent permitted by law, Buyer shall protect, defend, indemnify and hold harmless Seller, its directors, officers, shareholders and employees (collectively "Seller") from and against any and all manner of actions, claims, demands, damages, losses, liabilities, penalties, judgments, costs and expenses of any kind whatsoever (including without limitation, attorneys' and consultants' fees and expenses), whether in law or in equity or otherwise, arising out of or relating to (i) any inaccurate or faulty specifications supplied by Buyer, or (ii) any infringement or alleged

infringement of any patent, trademark, design or other intellectual property rights resulting from Seller's compliance with Buyer's specifications, or (iii) any personal injuries or property damage sustained or allegedly sustained by any person (including, but not limited to, Seller's agents and employees) as a result of Buyer's active or passive negligence or misconduct; or (iv) Buyer's or any third party's failure to test and determine the suitability of any item for Buyer's or any other intended user; (v) Buyer's or any third party's misuse or failure to use any item in a manner that does not conform to the applicable item specifications or to the requirements of any applicable federal, state or local law or requirement; or (vi) any third party claims asserted against Seller as a result of Buyer's or any other third-party's use of any item purchased hereunder. The provisions of this paragraph shall survive the delivery of and payment for all items under this Agreement and shall apply irrespective of whether Seller is also actively or passively negligent or otherwise at fault. In addition, this indemnity specifically covers any claims that may be asserted by Buyer's employees, and Buyer hereby expressly waives, for purposes of this indemnity only, any immunity it may have under any worker's compensation or other law from liability for claims brought by Seller pursuant to this paragraph.

Buyer's indemnity obligations to Seller hereinabove shall not be limited by any limitation on the amount or type of damages, benefits or compensation payable by or for Buyer under worker's compensation acts, disability benefit acts or other employee benefit acts on account of claims against Seller by an employee of Buyer or anyone employed directly or indirectly by Buyer or anyone for whose acts Buyer may be liable. In no event shall Buyer's liability hereunder be limited to the extent of any insurance available to or provided by Buyer.

11. **GOVERNING LAW:** This Agreement shall be governed by, and construed in accordance with, the laws of the State of Maryland without regard to its conflicts of laws. Any and all disputes arising under this Agreement shall be resolved in a state or federal court of competent jurisdiction within the State of Maryland and Buyer hereby irrevocably submits to the jurisdiction of any such court for the resolution of any and all disputes arising hereunder.
12. **WAIVER OF BREACH AND SEVERABILITY:** Any failure by Seller at any time, or from time to time, to enforce or require the strict keeping and performance by Buyer of any of the terms or conditions of this Agreement shall not constitute a waiver by Seller of a breach of any such terms or conditions, nor shall it affect or impair such terms or conditions in any way, or the right of Seller at any time to avail itself of such remedies as it may have for any such breach or breaches of such terms or conditions. A waiver of any of the terms or conditions hereof must be in writing and signed by the Seller. Any such waiver shall not be deemed a continuing waiver, but shall apply solely to the instance to which the waiver is directed. If any term or condition of this Agreement, or portion thereof, is rendered unenforceable under the law, all remaining terms and conditions not affected by such determination shall remain in full force and effect and shall be binding upon the parties hereto.
13. **NO THIRD PARTY BENEFICIARIES:** Except as otherwise provided in writing, nothing contained in this Agreement shall be construed to give any rights or benefits in this Agreement to anyone other than Buyer and Seller, and all duties and responsibilities undertaken pursuant to this Agreement will be for the sole and exclusive benefit of Buyer and Seller and not for the benefit of any other party.
14. **SUCCESSORS AND ASSIGNS:** This Agreement shall be binding upon and shall inure to the benefit of the respective successors and assigns of both Seller and Buyer. Buyer shall not, however, assign this Agreement or any part thereof or the items hereunder without the prior written consent of Seller, which consent Seller may grant or withhold in its sole and absolute discretion.